

Production of stainless steel wire-reinforced aluminium composite sheet by explosive compaction

A. K. BHALLA, J. D. WILLIAMS

Department of Mechanical Engineering, The Queen's University of Belfast, Northern Ireland

Composite sheet material has been produced by explosively compacting stacks of alternately placed stainless steel wire meshes and aluminium foils. It was found that stacks could be satisfactorily bonded by using an aluminium driver plate which was prevented from bonding to the stack by interposing a polythene sheet. Stacks containing six or seven layers of mesh and having a wire volume fraction of up to 0.24 could be bonded when the driver plate kinetic energy exceeded 120 J cm^{-2} . It is concluded that the bonding mechanism involves cold pressure welding of the matrix metal by extrusion through the mesh apertures, and the aperture size is a controlling factor in bonding. No evidence was found of strong bonding between the wires and the matrix. In the production of larger sizes of composite sheet, (300 mm \times 500 mm), blistering and tearing occurred due to the presence of excess air in the stack, a consequence of bowing of the foils by the springy and curved pieces of mesh. This difficulty was overcome by enclosing the stack in a polythene envelope, which was evacuated before detonation of the charge, so that the stack was compressed by atmospheric pressure. Tests have shown that tensile and fatigue properties of the composites compare favourably with other aluminium matrix composites and with high strength aluminium alloys.

1. Introduction

Wire-reinforced metal matrix composite materials have been made by powder metallurgy techniques [1], infiltration of wires by molten matrix metal [2], hot rolling of wires between metal sheets [3] and diffusion bonding, i.e. hot pressing of wires between metal sheets [4]. All these methods involve the use of high temperature which can cause softening of cold drawn wires, and wire/matrix interactions that produce brittle intermetallic compounds and surface defects in the wires. As a result, the tensile strength of the composites may be reduced. In addition, these methods of production are subject to practical limitations in the size of composite that can be produced.

The use of explosive compaction in the production of wire-reinforced composites has been reported by various workers, [5-12]. In this

method, an assembly of wires and metal foils is compacted together by the detonation of an explosive charge, as shown in Fig. 1. This method of composite production does not suffer from the limitations mentioned above in that any high temperatures produced will exist for extremely

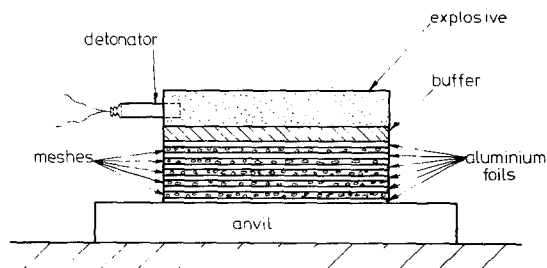

Figure 1 Assembly for explosive fabrication of mesh-reinforced aluminium composite.

short periods of time and the size of composite produced is not limited by the capacity of pressing equipment. In addition, the passage of explosive shock waves through the wires and matrix normally causes a rise in their yield stress which can enhance the mechanical properties of the composites. Practical difficulties associated with the handling of numerous wires in close proximity can be overcome by the use of woven wire meshes. However, because woven meshes do not normally incorporate high tensile wires, it is necessary to have meshes specially woven. The aims of the work reported here were:

(a) to examine the factors controlling the production of wire-reinforced metal matrix composites from meshes and foils;

(b) to produce a large piece of composite containing a wire volume fraction of approximately 0.25; and

(c) to evaluate the tensile and fatigue properties of the composite.

The materials chosen for this work were stainless steel wires and aluminium foil as matrix material, since both are readily available and their combination would allow the production of a composite with good strength to weight ratio.

2. Experimental details of composite production

The materials used in the production of the composites consisted of commercially pure aluminium foils, ranging in thickness from 0.127 to 0.69 mm, and various stainless steel meshes as detailed in Tables I and II. The aluminium foil

TABLE I Soft stainless steel meshes

Wire diameter (mm)	Wires/in. of mesh
0.193	40 × 40
0.254	40 × 40
0.152	60 × 60
0.193	60 × 60
0.132	80 × 80

TABLE II High tensile stainless steel meshes

Wire diameter (mm)	Wires/in. of mesh		Material
	Warp	Weft	
0.127	80		H.T. stainless
0.140		14	Soft stainless
0.127	60		H.T. stainless
0.140		14	Soft stainless
0.254	50		H.T. stainless
0.274		10	Aluminium

was prepared for bonding by abrading with 600 grit emery, followed by degreasing with acetone, and the meshes were thoroughly washed in acetone. Degreasing of the wire mesh was found to be essential, otherwise bonding was prevented, presumably by residual oil which was picked up in the weaving process. Stacks were prepared from several pieces of mesh interposed between aluminium foils, taped around the edges to keep them flat and thus minimize the amount of air contained within the stack. An explosive charge of dried Trimonite powder, contained in a wooden box with a flexible plastic base, was placed on top of the stack as shown in Fig. 1 and, after placing on a flat steel anvil, detonation was initiated with an electric detonator placed at the mid-point of a shorter side of the charge. In most cases, the dimensions of composites produced were 150 mm × 230 mm, although some larger composites were also made.

2.1. Preliminary tests

Initial attempts to produce the composites were made using meshes of soft stainless steel wire, UTS = 772 MPa, as detailed in Table I. Stacks containing four layers of 40 × 40, 0.193 mm diameter wire mesh and five layers of 0.69 mm thick aluminium foil were successfully compacted using a 9 mm thick explosive charge. The volume fraction of wire in these composites was 0.098, or 0.049 in each direction. In order to achieve higher volume fractions of wire, attempts were made to compact stacks made from aluminium foils in the thickness range from 0.127 to 0.254 mm using a 9 mm thick layer of explosive. This created fabrication problems of two types. Firstly, the use of such thin aluminium foils made it impossible to retain a flat, compressed stack by means of taping. As a result, the stack contained a considerable amount of air and, on compaction, fracture of the composite occurred. Secondly, it was observed that the uppermost layers of the stack were not bonded together. In order to overcome these difficulties, it was decided to use thicker aluminium plates on the top and base of the stack, with polythene sheets interposed to prevent welding of the thick plates to the stack. Using this method, a composite was made from seven layers of 40 × 40, 0.254 mm diameter wire and eight layers of 0.254 mm thick aluminium foil with full bonding and no fracture. The explosive charge was 9 mm thick and the aluminium driver

plate and base plate were 1.22 mm thick. This gave a total volume fraction of wire equal to 0.37 or 0.185 in each direction and a micro-section of this composite is shown in Fig. 2. Attempts to bond composites containing the three remaining meshes detailed in Table I were unsuccessful.

2.2. Incorporation of high tensile stainless steel wires

Meshes were produced from high tensile stainless steel wire as specified in Table II. The high tensile wires had tensile strengths of 2008 and 1850 MPa for diameters of 0.127 and 0.254 mm, respectively. Initial tests were made with meshes consisting of the 0.127 mm diameter wire, supported by a soft stainless steel wire weft. Attempts were made to bond together stacks containing up to fourteen layers of these meshes between aluminium foils of thickness 0.127 and 0.254 mm, using driver plates of 1.22 and 1.93 mm thickness, driven by 9 mm

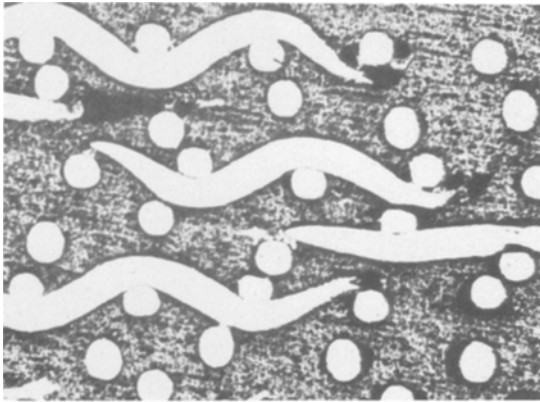

Figure 2 Microstructure of steel mesh/aluminium composite, $\times 25$.

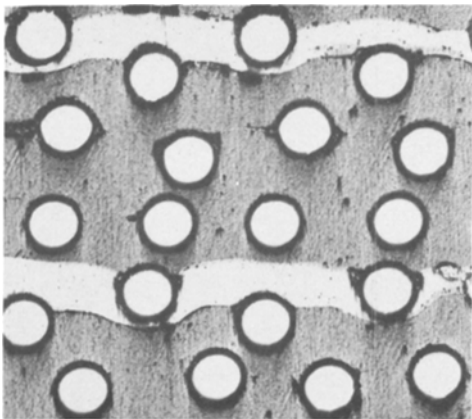

Figure 3 Microstructure of high tensile wire mesh/aluminium composite, $\times 32$.

thick explosive charges. In all cases, the high tensile stainless steel wires fractured during compaction at their points of interaction with the soft steel wires. As a result of the fracturing of wires lying in the direction of detonation, fracturing of the composites occurred so that only about 30% of the total composite area remained intact when 0.127 mm thick foils were used, and 60% remained intact when 0.254 mm thick foils were used.

To avoid the problem of wire fracture, and to permit a higher volume fraction of wire, the 50×10 , stainless steel/aluminium mesh was woven. Stacks containing seven layers of this mesh with 0.254 mm thick aluminium foil were successfully bonded without wire fracture using 1.22 mm thick driver plates, driven by a 9 mm thick explosive charge. These composites contained a volume fraction of stainless steel of 0.24 in the principal direction, and a micrograph of the structure is shown in Fig. 3.

3. Bonding mechanism and parameters

The term "explosive welding" has frequently been used to describe the process whereby bonding of wires and foils occurs. Explosive bonding occurs when two surfaces collide at an oblique angle of impact and at sufficient relative velocity to cause plastic flow at the line of contact, forming a fluid-like jet which often gives rise to an interfacial waveform [13]. During the compaction of foils and meshes, the collision geometry will vary periodically as the foil flows around the mesh wires and into the gaps, where it encounters metal from an adjacent foil, flowing in the opposite direction. It is doubtful, therefore, that the mechanism is similar to the case of explosive bonding between plane surfaces on oblique impact.

In order to check this hypothesis, attempts were made to bond foil/mesh stacks under conditions of normal (non-oblique) impact, such that explosive welding would not occur. Two arrangements were employed to achieve normal impact conditions, each being applied to stacks of foils and meshes and to stacks of foils only, to determine whether any welding took place. In the first arrangement, an explosive charge measuring $50 \text{ mm} \times 50 \text{ mm}$ was detonated at 25 points, 10 mm apart, by the use of 25 lengths of cordtex explosive, connected to a single detonation source. The second arrangement is shown in Fig. 4, and normal impact of the driver plate with the stack is achieved when $\sin \alpha = V_P/V_D$, where V_P is the

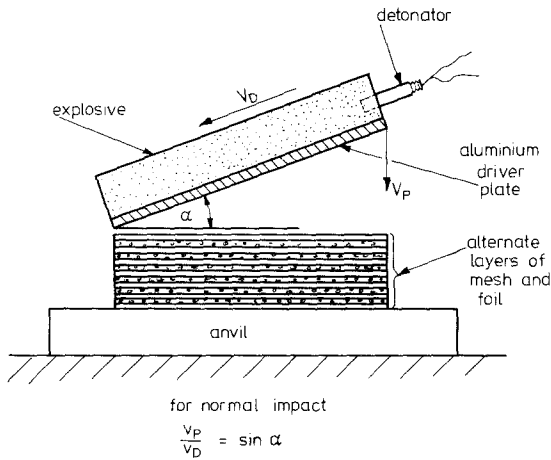

Figure 4 Explosive welding of mesh and foils under normal impact conditions.

plate velocity and V_D is the detonation velocity. Neither arrangement permitted welding between foils in the absence of meshes, whereas in their presence, well bonded composites were produced.

It is possible that the mutually impinging tongues of metal from adjacent foils might meet the oblique collision conditions for explosive bonding, but no evidence was found for wave formation at the interface, and it is more likely that bonding is achieved by the flowing together of newly exposed, clean aluminium, as is the case in cold pressure welding.

In the bonding arrangement shown in Fig. 1, the driver plate is rapidly accelerated by the explosive detonation to a velocity, V_P , which is related to the specific loading ratio, R , given by the mass of explosive divided by the mass of driver plate per unit area. Experimentally deter-

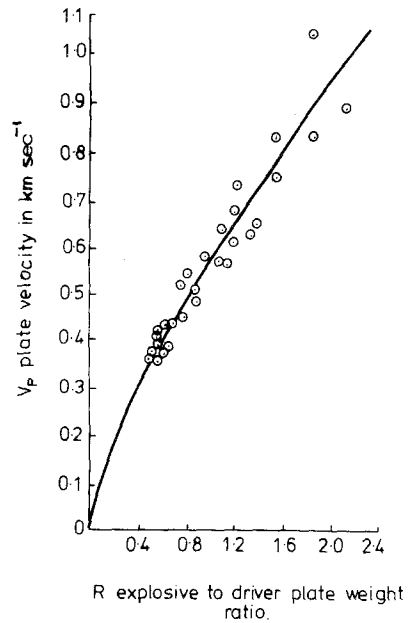

Figure 5 Variation of V_P with R for Trimonite no. 1 explosive.

mined values of V_P [14] are shown in Fig. 5. The impact pressure arising from the collision of two plates of similar material is given by;

$$P_i = \frac{1}{2} \rho \cdot V_P \cdot V_S \quad (1)$$

where ρ is the density of the plates, V_P their approach velocity and V_S the velocity of sound in them. From this it is estimated that pressures arising from the collision of the driver plate with the top foil of the stack are in the range 4 to 7 GPa. In practice these estimates are high since they relate to normal impact whereas in the bonding operation the collision is oblique. Attempts were

TABLE III Effect of driver plate velocity and kinetic energy in bonding

	Driver plate thickness (mm)	Aluminium foil thickness (mm)	Mesh specification	Explosive thickness (mm)	Number of mesh layers	$R = \frac{E_m}{D_m}$	V_P (m sec ⁻¹)	E_k (J cm ⁻²)	Remarks
1	0.533	0.254	40 × 40 × 0.254	9	7	5.0	1,750	220	Weld
2	1.22	0.254	40 × 40 × 0.254	9	6, 7	2.1	970	155	Weld
3	1.22	0.254	50 × 10 × 0.254	9	6, 7	2.1	970	155	Weld
4	1.22	0.127	80 × 14 × 0.127	9	13	2.1	970	155	Weld
5	1.22	0.254	80 × 14 × 0.127	9	11	2.1	970	155	Weld
6	1.6	0.254	80 × 14 × 0.127	9	9	1.56	780	131	Weld
7	1.93	0.127	80 × 14 × 0.127	9	13	1.3	680	120	Weld
8	3.17	0.254	40 × 40 × 0.254	12	7	1.1	600	158	Weld
9	2.54	0.127	80 × 14 × 0.127	7	8, 5, 3	0.8	500	86	No weld
10	2.54	0.127	80 × 14 × 0.127	9	11	1.0	550	103	No weld
11	1.22	0.127	60 × 14 × 0.127	7	9, 7	1.6	800	105	No weld
12	3.17	0.127	80 × 14 × 0.127	9	2, 4, 7	0.8	500	106	No weld
13	1.22	0.254	40 × 40 × 0.254	9	2, 4, 5	2.1	970	155	No weld

made to bond together a stack of meshes and foils, pressed between two conical steel dies of contact area 100 mm². At a pressure of 0.3 GPa the high tensile steel wires were found to have broken from lack of ductility, and no bonding had occurred.

The specific kinetic energy of the moving plate is given by:

$$E_k/\text{unit area} = \frac{1}{2}\rho \cdot t \cdot V_p^2 \quad (2)$$

where ρ is the density of the plate and t is its thickness. Table III shows the experimental details of bonding arrangements used, including driver plate velocity and kinetic energy. It is clear that no bonding was achieved in stacks with up to eleven meshes when a kinetic energy less than 120 J cm⁻² was used. In tests 9, 10 and 12, the plate velocity was lower than in tests 1 to 8, although the fact that it was higher in test 11 than in test 6 would suggest that the kinetic energy of the driver plate is of greater importance than its velocity.

The experimental details shown in Table IV draw attention to the importance of mesh aperture in the bonding process. Using a driver plate energy in the range from 120 to 220 J cm⁻², it was found that no welding occurred with nominal mesh apertures of 0.186, 0.230 and 0.271 mm, while welds were effected when at least one dimension of the mesh aperture was 0.381 mm or greater. It

TABLE IV Effect of mesh aperture size and open area in bonding

Mesh specification	Aperture size (mm)	Wire diameter (mm)	Open area (%)	Remarks
40 × 40	0.381	0.254	36	Weld
40 × 40	0.441	0.193	48	Weld
60 × 60	0.23	0.193	29	No weld
80 × 80	0.186	0.132	34	No weld
60 × 60	0.271	0.152	40	No weld
80 × 14	0.19 × 1.67	0.127	55.8	Weld
60 × 14	0.29 × 1.67	0.127	64.7	Weld
50 × 10	0.254 × 2.26	0.254	44.5	Weld

would appear that there is a minimum aperture size into which aluminium can be made to flow with a driver plate energy in a given range. Further, it would appear from Table IV that the percentage open area of the mesh is not the controlling factor in bonding, since an open area of 40% with an aperture size of 0.271 mm failed to bond using driver plate energies of up to 240 J cm⁻², while an open area of 36% with an aperture size of 0.381 mm did allow bonding for a driver plate energy of 155 J cm⁻².

4. Production of large areas of composite

Using the 50/10 stainless steel/aluminium mesh, and bonding conditions described above to give bonded composites with a volume fraction of 0.24 of 0.254 mm diameter wire, attempts were made to produce composites with dimensions 300 mm × 500 mm. Initial attempts produced composites which contained fractures and blisters and this was attributed to the fact that taping around the edges did not hold the stack in a flat and compressed state. This problem was overcome by placing the stack in a polythene bag, which was then evacuated by a rotary pump, and a vacuum of about 15 mm Hg was held while the charge was detonated on the outside of the bag. In this way, several sound composites were produced and specimens were taken from them for mechanical testing. Owing to the expense of weaving small quantities of this special mesh, larger areas of composite were not attempted, although there should be no reason why larger sheets could not be prepared.

5. Tensile testing of composites

Three tensile specimens were made from each of the 150 mm × 230 mm composite sheets. Tensile tests were made with a Hounsfield Tensometer, using a 50.8 mm gauge length extensometer. The results are shown in Figs. 6 and 7, and in Table V.

TABLE V Average ultimate tensile strength of mesh-reinforced aluminium composites

Mesh specification	Wire volume fraction (%)	σ_m (MPa)	Observed UTS (MPa)	Theoretical UTS (MPa)	Efficiency (%)
40 × 40 × 0.193	4.9	77	124	111	> 100
40 × 40 × 0.193	11.0	72	139	149	93
40 × 40 × 0.254	13.9	70	147	168	87
40 × 40 × 0.254	18.5	59	173	190	90
50 × 10 × 0.254	24.0	28	453	465	97

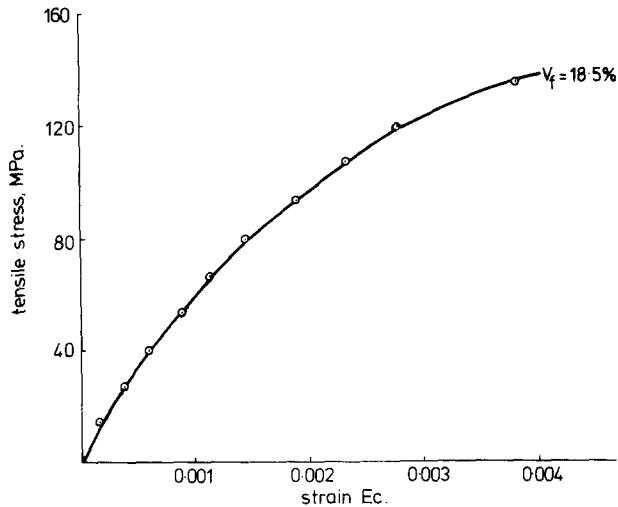

Figure 6 Stress/strain curve for ductile steel mesh-reinforced aluminium composite.

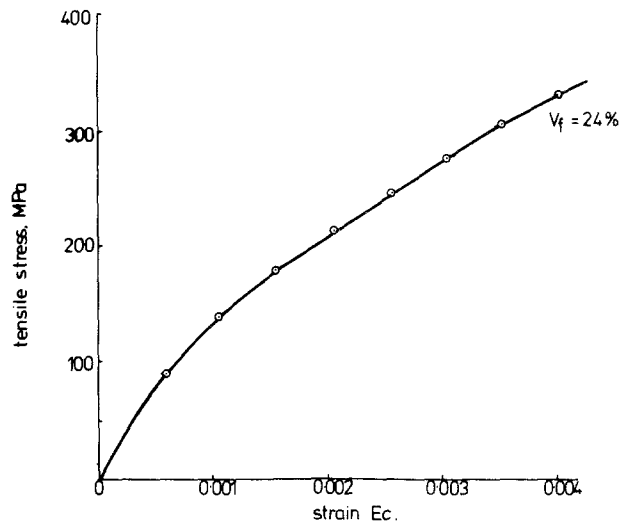

Figure 7 Stress/strain curve of high tensile stainless steel mesh-reinforced aluminium composite.

The theoretical tensile strengths of the composites, σ_c , were calculated from the equation:

$$\sigma_c = \sigma_f V_f + \sigma'_m (1 - V_f) \quad (3)$$

where σ_f is the tensile strength of the wires, V_f the volume fraction of the wires, and σ'_m is the stress in the matrix at the fracture strain of the wires. This latter value was obtained from tensile tests on specimens taken from explosively welded aluminium foils, so as to be representative of the matrix in the shocked state. It has been reported [15] that in composites made from relatively ductile wires, which fail in tension with necking, fibre fracture may occur at a larger strain than the fracture strain of an individually tested wire. In the present work, the fracture strain of the wires in the composite was found to vary with V_f , and

values of σ'_m for composites containing both types of wire, in various volume fractions, are given in Table V.

The tensile strengths of composites containing the softer stainless steel wires in volume fractions of 0.11, 0.139 and 0.185 in each direction were all significantly lower than the predicted values. Similar behaviour has previously been reported [16] for composites of explosively compacted tungsten wires and copper foils. In the present work, this behaviour might be due to pinching of the wires at overlap points in the mesh and/or an effective decrease in matrix cross-section caused by transverse wires not bonded to the matrix. The test pieces usually fractured along a shear plane at approximately 45° to the specimen axis, and very little pull out of wires was seen. The

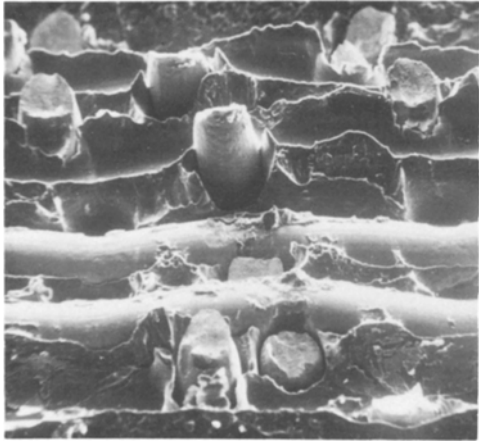

Figure 8 Tensile fracture surface of soft stainless steel mesh/aluminium composite, $\times 45$.

elongation to fracture decreased with increasing volume fraction of wires. A micrograph of the fracture surface (Fig. 8), shows that, although the matrix has flowed around the wires to give good contact, the clean separation due to necking suggests that full bonding had not occurred between the wires and the matrix.

As already reported, composites made from meshes containing high tensile wires, held by soft steel transverse wires, suffered from fracture of the wires at their overlap points. As a result, the tensile strengths of these composites were very unreliable. By contrast, composites made from the mesh containing aluminium cross wires, having a volume fraction of steel wires of 0.24, showed an efficiency of 97% and their UTS value of 453 MPa was almost six times that of the aluminium matrix.

Values of Young's modulus determined from the tensile tests were less than the theoretical

values for composites containing soft stainless steel wire mesh, whereas the composite containing 0.24 volume fraction of high tensile wires had modulus values significantly greater than the theoretical moduli.

6. Fatigue testing of composites

By means of an Amsler High Frequency Vibrophore testing machine, fatigue tests were carried out on specimens taken from composite sheets containing 0.24 volume fraction of high tensile stainless steel wire. Testing was done at a frequency of 90 Hz with a mean load to maximum load ratio of 1.1 to 2.1. An automatic load maintainer ensured that the mean load remained constant throughout each test and the results were expressed in terms of the number of cycles to cause complete fracture of the test piece.

As shown by Fig. 9, the fatigue stress limit for a life of 10^7 cycles was found to be 110 MPa, which is 1.43 times the ultimate tensile stress of the matrix and 0.24 times that of the composite. Assuming the fatigue stress limit at 10^7 cycles for the matrix to be about one third of its UTS [3, 17], i.e. 25 MPa, the corresponding fatigue stress limit of the composite is greater by a factor of more than four. By reference to fatigue data reported for other aluminium matrix composite materials, it is noted that the ratio of the composite's fatigue stress limit to its UTS compares favourably with ratios found for composites of aluminium/steel [3], aluminium/silica [18] and aluminium/carbon [17]. Results reported for aluminium/beryllium composites [19] showed that although the composite fatigue life was greater than that of the aluminium alloy matrix at all fatigue stress levels,

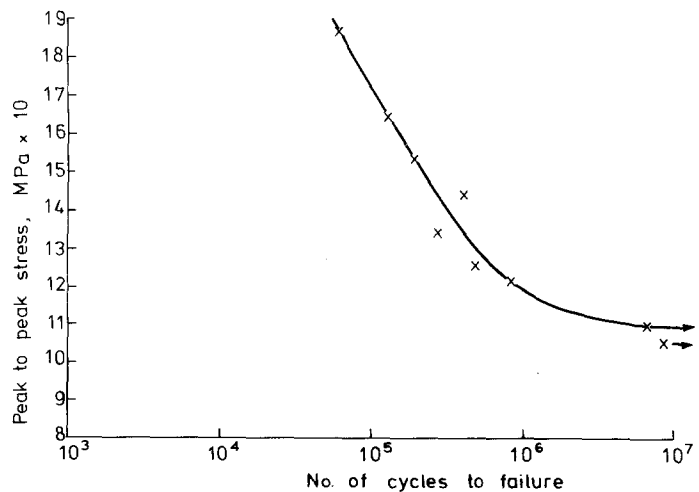

Figure 9 S/N curve for aluminium-24 vol % stainless steel wire-reinforced composite. Specimens tested in tension-tension.

the fatigue stress limit at 10^7 cycles was only 0.68 times the UTS of the matrix. On the other hand, results of tests on copper/tungsten composites [20] have indicated a fatigue stress limit at 10^6 cycles equal to 0.89 times the composite's UTS. It would appear that direct and meaningful comparison of fatigue results for the above composites is difficult due to differences in such factors as: (a) mode of fatigue testing; (b) method of composite manufacture; (c) fibre dimensions; (d) relative values of elastic moduli of fibres and matrix; and (e) degree of interfacial bonding of fibres and matrix.

Metallographic examination of longitudinal sections taken near to the fracture region of fatigue test pieces indicated that in some instances, fatigue cracks had propagated continuously through the matrix and wires (see Fig. 10). From this it would appear that there is sufficient friction at the wire/matrix interface to allow the fracture

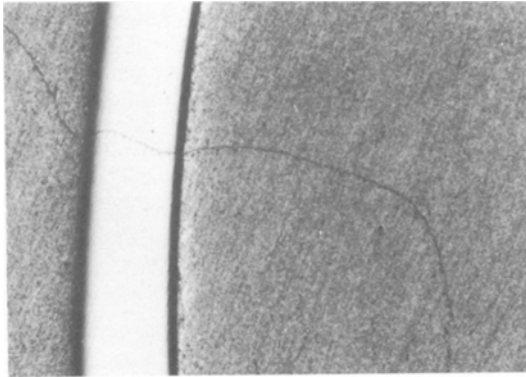

Figure 10 Fatigue fracture through wire and matrix, $\times 100$.

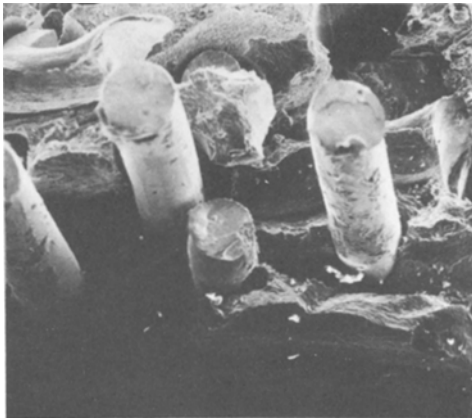

Figure 11 Fatigue surface of high tensile stainless steel mesh/aluminium composite, $\times 40$.

to grow across it. Referring to Fig. 11, which shows a scanning electron micrograph of the fracture surface, it can be seen that fatigue failures have occurred in some of the wires. Also evident were ductile cup and cone fractures which would have occurred during final stages of fracture as these remaining wires were stressed to their tensile limit.

7. Conclusion

It is clear from the above that soundly bonded composite sheets can be produced by explosive compaction of stacks containing stainless steel wire meshes and aluminium foils. Using high tensile stainless steel wires of 0.254 mm diameter, and foil 0.254 mm thick, composites were made with a wire volume fraction equal to 0.24 in one direction. No attempt was made to regulate the positioning of meshes relative to each other laterally, although offsetting the wires by a half mesh spacing might be beneficial.

Tensile and fatigue tests have shown that the explosively compacted composites have satisfactory mechanical properties in that the UTS is about six times higher than that of the matrix and the fatigue stress limit at 10^7 cycles was 1.43 times the UTS of the matrix. Although hot tensile tests were not done, it might be anticipated that the tensile properties of the composite after exposure to temperatures above 200°C would exceed those of aluminium alloys with comparable strength at lower temperatures.

It has been found that the use of a non-bonding driver plate overcomes problems of failure to bond and fracture of the mesh-foil combination. The role of the driver plate is to transmit to the stack the energy released by the detonation of the explosive in such a way that the peak pressure depends upon its velocity, and therefore on the loading ratio R , while the duration of the pressure pulse depends upon its thickness. It would appear from the results that the kinetic energy of the driver plate must be greater than a minimum value to achieve satisfactory bonding of a given combination of meshes and foils. Thus, it was found that a driver plate kinetic energy of 120 J cm^{-2} was satisfactory for bonding stacks containing six or seven meshes, although no bonding was effected in stacks with two to five meshes, Table III. Stacks with more than seven meshes were very erratic in their bonding response to this energy input.

It has been concluded that the bonding mechanism is not strictly that of explosive welding as commonly accepted, but rather a cold pressure welding of the foil material as it is extruded between the mesh wires. Indeed, it has been shown by Wylie [21] that impact energies needed to explosively weld aluminium to steel are much higher than those used in this work and this, together with the apparently clean separation of matrix from the wires, as shown in Fig. 8, would suggest that there is little bonding between the steel and the aluminium in these composites. Associated with this proposed welding mechanism, it would appear that there is a minimum mesh aperture size which will permit metal from the foils to flow into the aperture, and this is more critical than the total percentage of open area of the mesh.

Finally, it would appear that large areas of wire-reinforced composite could be produced by means of explosive compaction, provided that the stack is sufficiently compressed prior to compaction, as was achieved by enclosing in an evacuated polythene bag, to eliminate air which would cause blistering and fracturing of the composite.

Acknowledgements

The work reported was part of a research project supported by the Science Research Council and A.K.B. is grateful to this Council for personal support during the project. Both authors wish to thank The Queen's University of Belfast and Professor B. Crossland for facilitating this work. The assistance in various practical aspects given by Mr W. Kane and Mr J. Kelso is also gratefully acknowledged.

References

1. D. CRATCHLEY, *Powder Met.* **11** (1963) 59.
2. D. L. McDANIELS, R. W. JECH and J. W. WEETON, *Trans. Met. Soc. AMIE* **223** (1965) 636.
3. P. J. E. FORSYTH, R. W. GEORGE and D. A. RYDER, *Appl. Mat. Res.* **3** (1964) 223.
4. H. W. RAUCH, W. H. SUTTON and L. R. McCREIGHT, "Ceramic Fibres and Fibrous Composite Materials" (Academic Press, 1968) p. 180.
5. C. V. JARVIS and P. M. B. SLATE, *Nature* **220** (1968) 782.
6. O. Y. REECE, *Iron Age* (1970) 60.
7. J. FLECK, D. LABER and L. LEONARD, *J. Composite Mat.* **3** (1969) 699.
8. O. Y. REECE, Proceedings of the 3rd International Conference, Centre for H.E.F. Denver (1971) 2.1.
9. H. K. WYLIE, J. D. WILLIAMS and B. CROSSLAND, *ibid.*, 2.2.
10. P. M. B. SLATE and C. V. JARVIS, *J. Inst. Metals* **100** (1972) 217.
11. E. WOLFF and R. PRUMMER, *Space Travel Research*, **1** (1973) 16.
12. H. T. McCLELLAND and H. E. OTTO, Proceedings of the 4th International Conference for H.E.F. Denver (1973) 9.1.
13. B. CROSSLAND and J. D. WILLIAMS, *Met. Rev.* **15** (1970) Review 144.
14. V. SHRIBMAN and B. CROSSLAND, Proceedings of the 2nd International Conference for H.E.F. Denver (1960) 7.3.
15. A. KELLY and W. R. TYSON, *J. Mech. Phys. Solids* **13** (1965) 329.
16. C. V. JARVIS and P. M. B. SLATE, A.W.R.E. Report No. GRO/44/82/24, (1970).
17. A. A. BAKER, D. M. BRADDICK and P. W. JACKSON, *J. Mater. Sci.* **7** (1972) 747.
18. A. A. BAKER, *ibid.* **3** (1968) 412.
19. A. TOY, *J. Materials* **3** (1968) 43.
20. S. J. HARRIS and R. E. LEE, *Composites* (May 1974) 101.
21. H. K. WYLIE, Ph.D. Thesis, The Queen's University of Belfast (1971).

Received 26 January and accepted 16 July 1976.